



ACADEMIC  
PRESS

Available online at [www.sciencedirect.com](http://www.sciencedirect.com)

SCIENCE @ DIRECT®

Brain and Language 84 (2003) 286–305

Brain  
and  
Language

[www.elsevier.com/locate/b&l](http://www.elsevier.com/locate/b&l)

# Verb and auxiliary movement in agrammatic Broca's aphasia

Roelien Bastiaanse<sup>a,\*</sup> and Cynthia K. Thompson<sup>b</sup>

<sup>a</sup> *Department of Linguistics, Graduate School for Behavioral and Cognitive Neurosciences (BCN), University of Groningen, P.O. Box 716, 9700 AS Groningen, The Netherlands*

<sup>b</sup> *Department of Communicative Sciences and Disorders, Northwestern University, Evanston, IL, USA*

Accepted 25 June 2002

---

## Abstract

Verb production in agrammatic Broca's aphasia has repeatedly been shown to be impaired by a number of investigators. Not only is the number of verbs produced often significantly reduced, but verb inflections and auxiliaries are often omitted as well (e.g., Bastiaanse, Jonkers, & Moltmaker-Osinga, 1996; Saffran, Berndt, & Schwartz, 1989; Thompson, Shapiro, Li, & Schendel, 1994, 1997). It has been suggested that these problems are, in part, caused by the fact that finite verbs need to be moved from their base-generated position to inflectional nodes in the syntactic tree (e.g., Bastiaanse & Van Zonneveld, 1998). Others have suggested that production deficits in agrammatism can be predicted based on the position that certain structures take in the syntactic tree (Friedmann & Grodzinsky, 1997; Hagiwara, 1995). If the former theory is correct, several predictions can be made. First of all, the discrepancy between production of finite verbs in the matrix and embedded clause that has been found for Dutch (Bastiaanse & Van Zonneveld, 1998) should not be observed in English, since the word order of the matrix and embedded clause are the same in the latter language. Second, if verb movement (including movement of auxiliaries) is problematic for speakers with agrammatic aphasia, then a hierarchy in the production of auxiliaries in yes/no questions, auxiliaries, and finite verbs in declarative sentences in English would be expected, since the former has been moved and the two latter are in base-generated position. In the present paper, these hypotheses were tested in a cross-linguistic study of Dutch and English. Results showed the position in the syntactic tree does not predict deficit patterns; rather the critical factor appears to relate to whether or not verb or auxiliary movement is required.

© 2002 Elsevier Science (USA). All rights reserved.

*Keywords:* Agrammatism; Broca's aphasia; Verbs; Verb movement; Auxiliaries; Cross-linguistic studies

---

## 1. Introduction

It has been repeatedly shown that verb production in agrammatic Broca's aphasia is compromised at both the word and the sentence level (see, for example, Bastiaanse

---

\* Corresponding author.

*E-mail address:* [y.r.m.bastiaanse@let.rug.nl](mailto:y.r.m.bastiaanse@let.rug.nl) (R. Bastiaanse).

& Jonkers, 1998; Berndt, Haendiges, Mitchum, & Sandson, 1997a; Berndt, Mitchum, Haendiges, & Sandson, 1997b; Jonkers, 2000; Kim & Thompson, 2000; Kohn, Lorch, & Pearson, 1989; Miceli, Silveri, Villa, & Caramazza, 1984, 1988; Thompson et al., 1994, 1997). It has been suggested that production of verbs at the sentence level is influenced by both semantic and morphosyntactic variables. Thompson et al. (1997) and Kim and Thompson (2000) showed that verb argument structure affects the retrievability of verbs, i.e., the ease with which English speaking agrammatic aphasics retrieve a verb is related to both the number of arguments that accompany the verb and the number of possible argument structures. Bastiaanse and Jonkers (1998) also showed that there is a relation between the diversity of verbs in the spontaneous speech of Dutch agrammatic aphasics and the proportion of finite verbs, in that poor diversity of lexical verbs is related to a relatively high proportion of finite clauses, whereas a (close to) normal diversity of verbs goes with a lower than normal proportion of finite verbs. Morpho-syntactic problems are mentioned by Saffran et al. (1989) and Thompson et al. (1994), who showed that in English speaking agrammatics verb morphology is impaired, and by Bastiaanse and Van Zonneveld (1998) who suggested that problems with finite verbs are due to the structure of Dutch. The present paper focuses on the morpho-syntactic problems of Dutch and English speaking agrammatic speakers with emphasis on the production of finite verbs. Due to the cross-linguistic differences between Dutch and English, we postulate different deficit patterns in aphasic speakers of the two languages.

## 2. Cross-linguistic differences between Dutch and English

Dutch is a so-called SOV-language, which means that the basic word order is subject–object–verb, as can be seen in the Dutch embedded clause in (1).

- (1) I see that [dat de jongen een boek leest]  
 I see that [that the boy a book reads]  
 (I see that the boy reads a book)

In contrast, in the matrix clause, the finite verb or auxiliary moves to second position, following a syntactic rule, called *Verb Second* (V2), as shown in (2)–(3) below. Notice that in (3) the non-finite lexical verb (*gelezen*: ‘read’) remains in its base-generated position, showing that this is the original position of the verb.

- (2) de jongen leest<sub>i</sub> een boek t<sub>i</sub>  
 the boy reads a book  
 (3) de jongen heeft<sub>i</sub> een boek gelezen t<sub>i</sub>  
 the boy has a book read  
 (the boy has read a book)

The Dutch embedded and matrix clause are shown graphically in Fig. 1. We follow Chomsky’s (1995) approach that the verb comes fully inflected from the lexicon and its features are checked overtly in the matrix, but not in the embedded clause, where it remains in situ.

In English, the basic word order is subject–verb–object and the features of the finite verb do not need to be checked overtly in the matrix or the embedded clause. Hence, there is no verb movement. As can be seen in (4)–(5) the verb remains in V. To further illustrate, the syntactic trees for English matrix and embedded clauses are shown in Fig. 2.

- (4) the boy reads the book  
 (5) I see [that the boy reads the book]

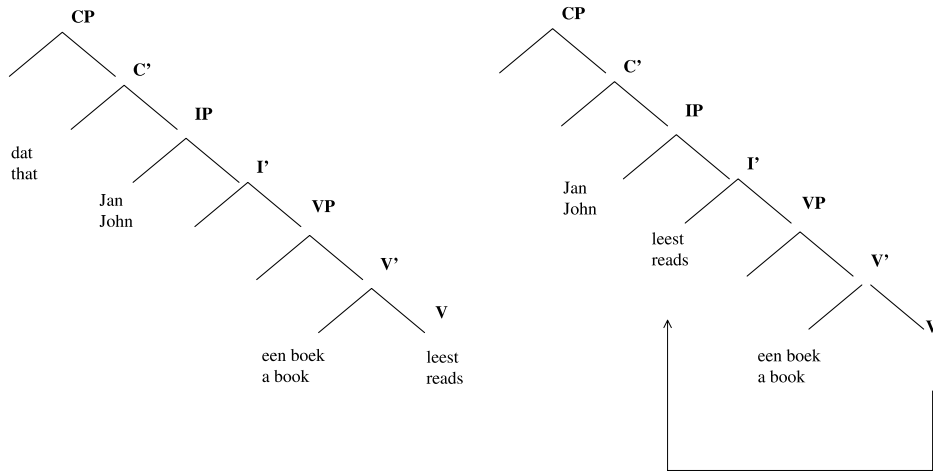

Fig. 1. A graphic representation of the Dutch embedded (left) and Dutch matrix (right) clause. In the matrix clause the verb is moved to second position.

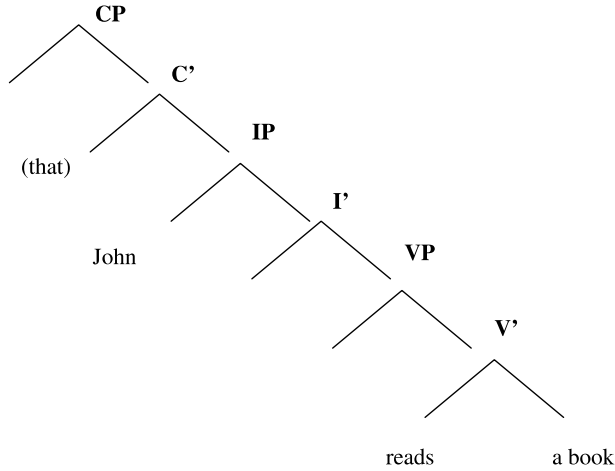

Fig. 2. A graphic representation of the English matrix and embedded clause. There is no overt movement of the verb.

For auxiliary forms of *to be* and *to do*, it is assumed that in English these are base-generated in I (Lasnik, 1999). The same holds for all modal verbs. See Fig. 3.

This does not mean that verb movement does not occur in English. In fact, *yes/no* questions and object and adjunct questions require finite auxiliary movement in English as in (6)–(8). We show this movement for English *yes/no* questions in Fig. 4.

- (6) is the boy  $t_i$  reading the book?  
└──────────┘
- (7) what is the boy  $t_i$  reading?  
└──────────┘
- (8) where is the boy  $t_i$  reading the book?  
└──────────┘

In summary, the difference between Dutch and English is that in Dutch the finite verb in the matrix clause moves overtly to the second position, but remains in situ in the embedded clause; whereas in English, the finite verb remains in situ, both in the

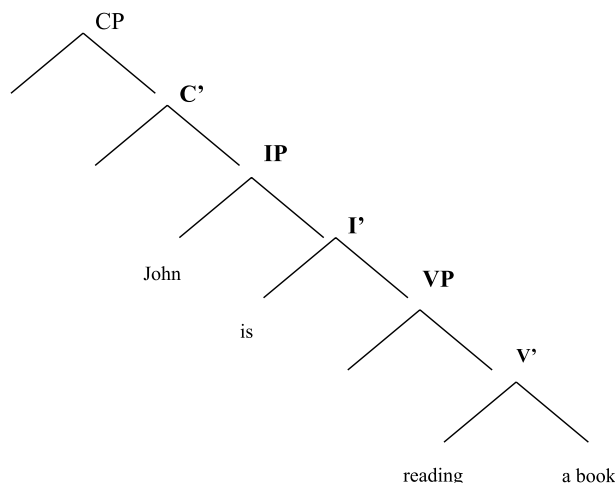

Fig. 3. A graphic representation of an English matrix clause with an auxiliary; *is* is base-generated in I.

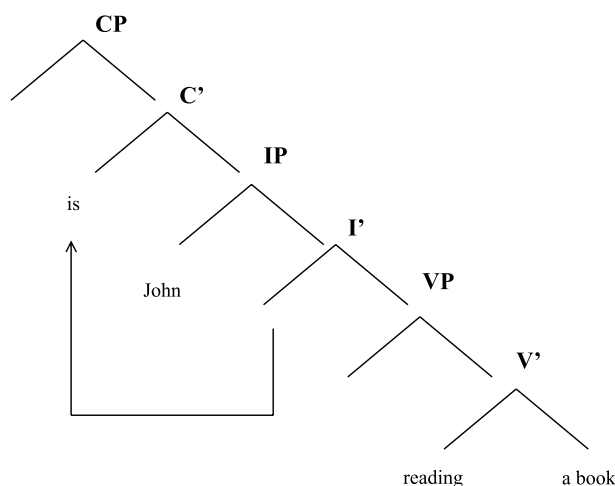

Fig. 4. A graphic representation of an English yes/no question. The auxiliary *is* is moved from I to C.

matrix declarative and in the embedded clause. For English it is additionally assumed that auxiliaries such as *is* are base-generated in I, and in some questions, there is movement of the auxiliary (to C) which is comparable to Dutch verb movement.

### 2.1. Aphasiological background

Bastiaanse and Van Zonneveld (1998) showed that Dutch speaking agrammatic Broca's aphasic individuals have more difficulty generating finite verbs in the matrix clause than in the embedded clause. They presented patients with an action picture with a sentence printed underneath, in which the finite verb was replaced by dots. The patients were asked to fill in the missing word (see Fig. 5).

The agrammatic aphasic patients studied showed significantly poorer performance in the matrix than in the embedded clause, and they often erred by providing an infinitive instead of a finite verb. Bastiaanse and Van Zonneveld, therefore, suggested that the problems with finite verbs as often described in Dutch agrammatic speech (Bastiaanse et al., 1996, 2002; Kolk & Heeschen, 1992) are the result of an

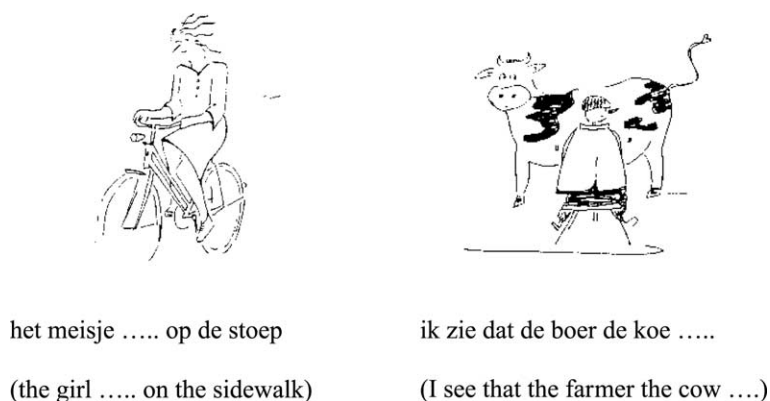

Fig. 5. Two examples of the stimuli used by Bastiaanse and Van Zonneveld (1998): filling in a finite verb in the matrix (left) and the embedded (right) clause. The targets are *bikes* and *milks*.

underlying syntactic impairment, i.e., agrammatic Broca's aphasics are compromised in applying Verb Second. If this assumption is true, then it is reasonable to hypothesize that the discrepancy between the production of finite lexical verbs in matrix and embedded clauses will not be found in English speaking agrammatics, since verb movement in this form is not part of the English grammar. The first study presented here evaluates this hypothesis.

Where Bastiaanse and colleagues restrict their theory to verb movement, others suggest that production deficits in agrammatism can be predicted by the position that certain structures occupy in the syntactic tree. Hagiwara (1995), for example, suggests that the CP-node is impaired in agrammatic aphasia and, therefore, that no functional projection can be realized in C. However, this implies that verb movement in Dutch should be unimpaired (although there are linguists who assume that the finite verb in Dutch moves to C and not to I). Similarly, the *tree pruning hypothesis*, advanced by Friedmann (Friedmann, 2000; Friedmann & Grodzinsky, 1997), postulates that functional projections to both C and I are impaired, but that C is more impaired than I. The findings of Bastiaanse and Van Zonneveld could be interpreted within this framework in that verb movement to I is impaired. However, for English this means that the production of finite lexical verbs (that remain in V) should be less impaired than the production of finite auxiliaries (that are base-generated in I), which should be less impaired than production of moved finite auxiliaries (that are moved to C). This latter hierarchy would not be expected on our verb movement theory. Rather, the verb movement hypothesis predicts that for English speaking agrammatic patients production of finite lexical verbs and finite auxiliaries in declarative sentences should be equally impaired (or intact), since they do not move (overtly); however, auxiliaries in yes/no questions should be more difficult to produce than non-moved auxiliaries and finite lexical verbs. The second study presented here evaluates this hypothesis.

### 3. Study 1

#### 3.1. Method

##### 3.1.1. Subjects

Fifteen agrammatic Broca's aphasic individuals were tested, nine with Dutch and six with English as their native language. All patients were right-handed, had normal

(or corrected to normal) hearing and vision, had at least a high school education, and were at least three months post-onset of a single, left hemisphere stroke at the time of the study. None of the patients had a history of drug or alcohol abuse, hospitalization for psychiatric disorder, developmental speech/language disorders, or prior neurological disease. The relevant data are provided in Table 1.

For the Dutch speaking group the diagnosis of Broca's aphasia was based on performance on the *Aachen Aphasia Test* (AAT, Graetz, De Bleser, & Willmes, 1992). The English-speaking patients were classified using the *Western Aphasia Battery* (WAB, Kertesz, 1982). All patients showed classic Broca's aphasia: verbal output was nonfluent and telegraphic and comprehension was relatively intact. In addition, in spontaneous speech all subjects produced few grammatical sentences, utterance length ranged from 3 to 6 words, they produced more open class than closed class words, and all had noted difficulty with verb production. None of the patients had articulation disorders to an extent that might have influenced the test results.

### 3.1.2. Materials and procedures

A sentence completion task consisting of 30 items was developed. Half of the items elicited a matrix clause and half elicited an embedded clause (see Appendix A for a complete listing of test items). For each item, a picture pair also was developed. Both pictures in the pair showed the same action performed by the same person, but on a different object (see Fig. 6). The same sentence completion test was used with both participant groups (Dutch and English), only the language in which the test was presented differed. Sample items in each language are provided in (9–12).

#### (9) Dutch matrix clause

Dit is de jongen die de tomaat snijdt en dit is de jongen die het brood snijdt. Dus deze jongen snijdt de tomaat en deze jongen ...

Patient: *'snijdt het brood'*

(This is the boy that the tomato cuts and this is the boy that the bread cuts. So, this boy cuts the tomato and this boy ...

Patient: *'cuts the bread'*)

Table 1

Age, gender, and time post-onset for the subjects of Study 1. D1–D9: Dutch participant, E1–E6: English participants

Patient	Age	Gender	Months post-onset
D1	27	Female	60
D2	44	Female	17
D3	38	Female	62
D4	53	Female	3
D5	67	Male	66
D6	50	Female	3
D7	33	Female	11
D8	20	Male	12
D9	45	Female	14
E1	54	Male	9
E2	65	Male	70
E3	63	Male	106
E4	42	Male	12
E5	55	Female	49
E6	60	Male	26

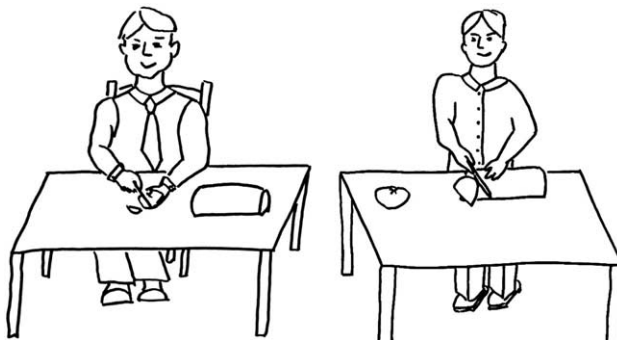

Fig. 6. Sample stimuli used in Study 1.

(10) Dutch embedded clause

Deze jongen snijdt de tomaat en deze jongen snijdt het brood. Dus dit is de jongen die de tomaat snijdt en dit is de jongen die ...

Patient: *'het brood snijdt'*

(This boy cuts the tomato and this boy cuts the bread. So, this is the boy that the tomato cuts and this is the boy that ...

Patient: *'the bread cuts'*

(11) English matrix clause

This is the boy that cuts the tomato and this is the boy that cuts the bread. So, this boy cuts the tomato and this boy ...

Patient: *'cuts the bread'*

(12) English embedded clause

This boy cuts the tomato and this boy cuts bread. So, this is the boy that cuts the tomato and this is the boy that ...

Patient: *'cuts the bread'*

Participants were asked to listen carefully to the experimenter as she/he read each item aloud, and to complete the final sentence read. The order of the items was randomized, with the restriction that each picture pair was shown once during the first 15 items and once during the last 15 items. Two practice trials were given using non-test stimuli and these were repeated when necessary until the patient understood what he was expected to do. On request of the patient, items were repeated once. Self-corrections were allowed and the final answer was scored. No instances of worsening of response appeared. No time limits were imposed.

The entire experimental session was audio-taped. During testing all subject responses were transcribed and afterwards checked against the recordings.

### 3.1.3. Scoring

Both quantitative and qualitative analyses were completed. For the quantitative analysis, the number of correct responses was simply tallied. Responses were considered correct when a properly inflected verb and an object were produced in the correct word order. Responses with determiner omission, semantic paraphasias of the object, and phonemic paraphasias were counted as correct. For the qualitative comparisons, an errors analysis was performed. Errors were classified post hoc based on the most frequent errors occurring in both languages. These included (a) verb omissions (e.g., the patient only produced the object), (b) finiteness omissions (i.e., production of infinitives/stems or gerunds), and (c) word order errors (e.g., production of an object followed by a finite verb for English matrix and embedded clauses and for the Dutch matrix clause; production of a finite verb followed by an

Table 2

Mean scores of the Dutch and English speaking agrammatic speakers. Maximum score is 30, 15 for the matrix and 15 for the embedded clause

	Matrix clause	Embedded clause	Total
Dutch	7.33	11.88	19.22
English	9.83	9.97	19.82

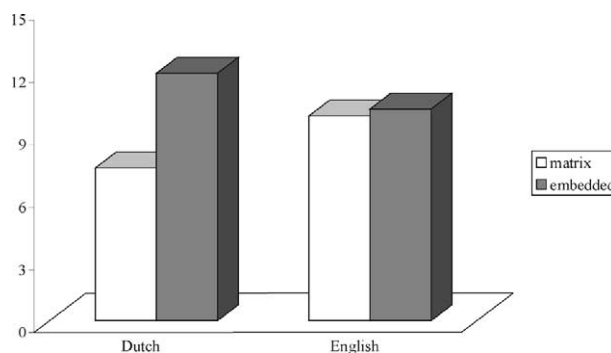

Fig. 7. Mean number of correctly produced items by Dutch and English subjects in Study 1 (maximum is 15).

object for the Dutch embedded clause). All other errors were coded as other (e.g., no response, unclassifiable errors).

### 3.2. Results

The group results are shown in Table 2 and Fig. 7 (data for individual subjects are included in Appendix B). Because of the small number of subjects per group, the data were analyzed using nonparametric statistics. The statistical analyses revealed no significant difference between the total number of correct responses produced by the two groups (mwu:  $z = -0.71$ ,  $p = .477$ ). However, for the Dutch group, there was a significant difference between production of matrix and embedded clauses (wilcoxon:  $z = -2.37$ ,  $p = .018$ ), that was not found for the English speaking patients (wilcoxon:  $z = -0.75$ ,  $p = .453$ ).

The error data are presented in Table 3 and in Fig. 8 (individual subject data are in Appendix B). These data showed that both patient groups omit verbs. However, the Dutch speaking participants, with the exception of one, omitted verbs only in the matrix clause; whereas, the English speaking participants omitted verbs mainly in the embedded clause. Notice that in both languages verb omissions in the matrix clause result in a grammatical sentence, e.g., *this boy cuts the tomato and this boy the bread*; however, this is not the case for the embedded clause, e.g., *\*this is the boy that cuts the tomato and this is the boy that the bread*. Because none of the patients consistently omitted the verb in the matrix clause and, when they did, they often indicate that this was not the expected response, we counted these omissions as errors.<sup>1</sup> For a linguistic account to justify our scoring, see Zuckerman, Bastiaanse, and Van Zonneveld (2001).

<sup>1</sup> If omissions in the matrix clauses are ignored, there is still a significant difference between the matrix and the embedded clause ( $z = -2.37$ ,  $p = .018$ ) in Dutch, whereas the difference for English remains nonsignificant ( $z = -0.52$ ,  $p = .603$ ).

Table 3

Total number of errors per type for the Dutch and the English speaking agrammatic speakers

	V-omission		Finiteness omission		Word order error		Other	
	Matrix	Emb.	Matrix	Emb.	Matrix	Emb.	Matrix	Emb.
Dutch <sup>a</sup>	25	3	0	0	22	11	12	14
English	5	12	16	13	0	0	6	4

<sup>a</sup>One Dutch patient produced 10 matrix clauses with a so-called *dummy verb* (to do): *deze jongen gooit de bal en deze jongen ... doet de stok* (this boy throws the ball and this boy ... does the stick).

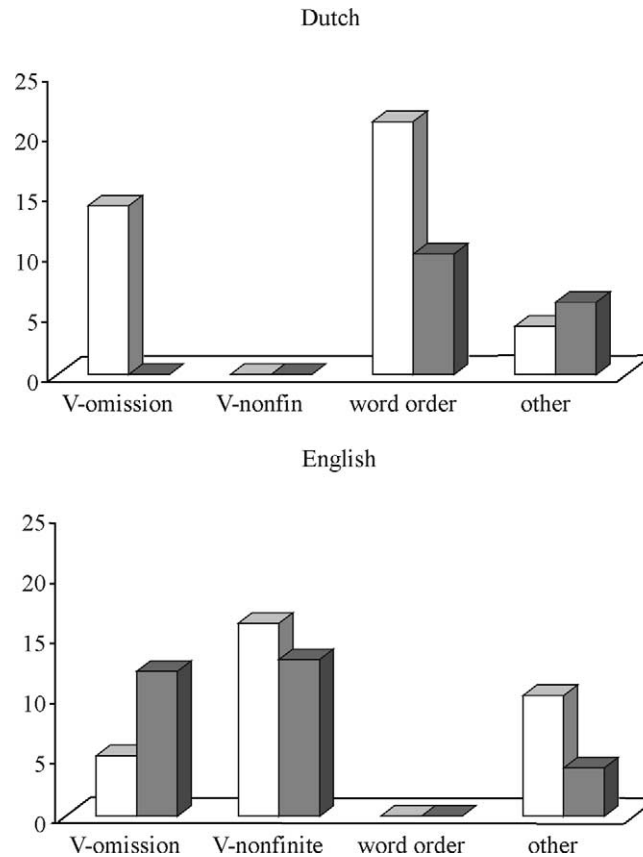

Fig. 8. Errors types in Dutch and English in Study 1.

Most interesting is the clear dichotomy in the errors produced by the two populations. The most prominent error of the Dutch patients was production of the wrong word order (i.e., embedded order in the matrix clause and vice versa), an error never made by the English speaking participants. In contrast, the most frequent error made by the English speaking patients was production of non-finite verbs (both infinitives/stems and gerunds), errors never made by the Dutch speaking agrammatics.

### 3.3. Summary and conclusion

Results of Study 1 showed the expected discrepancy between production of finite verbs in the matrix and embedded clause in the Dutch speaking agrammatic aphasic

participants. We also showed that this discrepancy is not seen in the English speaking agrammatic patients. These findings support our (first) hypothesis that verb movement is a critical factor in the production of finite verbs in agrammatic aphasia.

Our second hypothesis, that verb movement is indeed the critical factor, rather than the position of the finite verb in the syntactic tree, was tested for English speaking agrammatic patients in Study 2. Here we compared production of non-moved finite lexical verbs and auxiliaries with the production of moved auxiliaries.

## 4. Study 2

### 4.1. Method

#### 4.1.1. Subjects

Eight English speaking agrammatic Broca's aphasics were tested. All patients were right-handed, had normal (or corrected to normal) hearing and vision, had at least a high school education, and were at least three months post-onset of a single, left hemisphere stroke at the time of the study. None of the patients had a history of drug or alcohol abuse, hospitalization for psychiatric disorder, developmental speech/language disorders, or prior neurological disease. The relevant data are presented in Table 4. Five of these individuals (E1–E5) also participated in the first study.

All participants were diagnosed with Broca's aphasia based on results of the *Western Aphasia Battery* (WAB, Kertesz, 1982). Verbal output was nonfluent and telegraphic and comprehension was relatively intact for all patients. Spontaneous speech consisted of short, simple, largely ungrammatical sentences. All subjects produced more open class than closed class words, and more nouns than verbs. None of the patients had articulation disorders to an extent that might have influenced the test results.

#### 4.1.2. Materials and procedure

A set of 40 semantically reversible target sentences was developed using transitive verbs and animate agents and themes. The set included three target sentence types: (a) active declarative sentences with a finite lexical verb, that is assumed to stay in its base-generated position in English (the *V-in-V* condition; e.g., *The convict kicks the sheriff*) ( $n = 10$ ); (b) active declarative sentences with a finite auxiliary, assumed to be base-generated in I (the *Aux-in-I* position; e.g., *The convict is kicking the sheriff*) ( $n = 10$ ); and (c) yes/no question, in which the finite auxiliary moves to C (the *Aux-in C* condition; e.g., *Is the convict kicking the sheriff?*) ( $n = 20$ ). A complete list of the items is given in Appendix C.

Table 4  
Age, gender, and time post-onset for the subjects of Study 2

Patient	Age	Gender	Months post-onset
E1	54	Male	9
E2	65	Male	70
E3	63	Male	106
E4	42	Male	12
E5	55	Female	49
E6	48	Male	111
E7	62	Male	26
E8	51	Female	23



Fig. 9. Sample stimuli used to elicit target sentence types in Study 2.

For each item, a picture pair was developed with one picture in the pair depicting the target sentence and the other depicting its semantically reversed counterpart (see Fig. 9). To elicit the target sentences, a sentence production priming task was used. First, a picture pair was presented. The examiner then read a sentence corresponding with one of the pictures, and the patient was asked to describe the second picture using the same sentence structure used as the examiner. The items were presented in random order.

#### 4.1.3. Scoring

Both quantitative and qualitative analyses were completed. For the quantitative analysis, a simple correct–incorrect scoring system was used and the proportion of correct responses produced by sentence type was calculated. Responses were considered correct when the complete target sentence was produced with a properly inflected verb. Determiner omissions, semantic paraphasias of NPs and phonemic paraphasias were ignored. For the qualitative comparisons, an errors analysis was performed. Errors were classified post hoc based on those most frequently occurring in at least two patients. These included (a) production of the participle (or past tense) (V + ed) instead of required form, (b) production of V + ing instead of the finite verb, (c) production of the verb stem instead of the required form, (d) auxiliary omission, (e) movement failure, and (f) role reversal.

#### 4.2. Results

The proportion of responses produced correctly by sentence type by the agrammatic aphasic patients is presented in Table 5 and in Fig. 10 (see Appendix D for individual participant scores). As can be seen, the patients showed deficits in production of all sentence types tested. Statistical analysis comparing sentences with the finite lexical verb in its base-generated position (V-in-V) and the auxiliary in its base-generated position (Aux-in-I) revealed no significant differences between these sentence types (wilcoxon:  $z = -0.68$ ,  $p = .496$ ). However, when these two base-generated finite

Table 5

Mean percentages correct for the three experimental conditions: finite verbs in base-generated position (V-in-V; 10 items), auxiliaries in base-generated position (Aux-in-I; 10 items), total base-generated position (no movement; this is V-in-V + Aux-in-I; 20 items), and moved auxiliaries (Aux-in-C: +movement; 20 items)

V-in-V	Aux-in-I	No movement	Aux-in-C
39.16	35.00	37.08	15.63

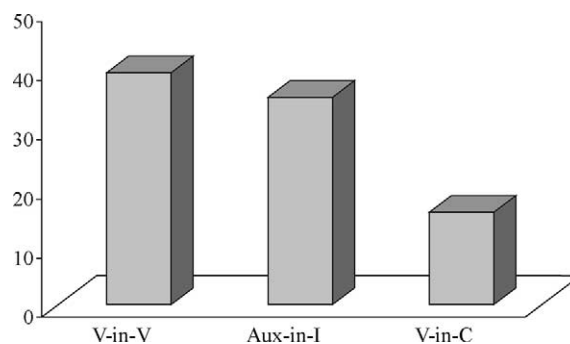

Fig. 10. Percentage correct production of V-in-V structures with no overt movement (10 items), Aux-in-I structures with no overt movement (10 items), and Aux-in-C structures with overt movement (20 items).

Table 6

Errors noted in the three experimental conditions (number of each type produced across participants): finite verbs in base-generated position (V-in-V; 10 items), auxiliaries in base-generated position (Aux-in-I; 10 items), and moved auxiliaries (Aux-in-C; 20 items)

	V-in-V	Aux-in-I	Aux-in-C
V+ed	15	4	8
V+ing	9	—	—
Stem	3	7	1
Auxiliary omission	0	12	23
Movement failure	—	—	24
Role reversal	0	2	2

forms were taken together and compared to the condition in which the auxiliary underwent verb movement (Aux-in-C), there was a significant difference in production (wilcoxon:  $z = 2.12$ ,  $p = .034$ ). That is, sentences with movement were produced significantly more poorly than those without movement. Further analysis showed that both sentences with V-in-V and sentences with Aux-in-I were better produced than sentences with Aux-in-C (V-in-V versus Aux-in-C:  $z = -2.11$ ,  $p = .035$ ; Aux-in-I versus Aux-in-C:  $z = -2.13$ ,  $p = .033$ ). These data support the hypothesis that finite verbs and auxiliaries in their base-generated positions are easier to produce than moved auxiliaries.

#### 4.2.1. Error analysis

The error data are presented in Table 6. For the V-in-V condition, the most frequent error was the production of a V+ed form, for example *kicked* for *kicks*. This can either be interpreted as a tense error (past tense) or as a participle. This error was produced 15 times across participants, but only two patients made this error more than once. In the AUX-in-I condition, the most frequent error was

omission of the auxiliary, for example, *kicking* for *is kicking*. Auxiliary omission occurred to a similar extent in the Aux-in-C condition. In the latter condition failure to move the auxiliary to C was an equally frequent error, though mainly caused by one patient who made this error 17 times.

#### 4.3. Summary and conclusion

For English speaking individuals with agrammatic aphasia, sentence production is more impaired when the auxiliary has been moved from its base-generated position than when the finite lexical verb or the auxiliary is in its base-generated position. The most frequent error in sentences where the finite lexical verb is in its base-generated position was production of the verb + ed, which can either be interpreted as tense errors or as a participle errors. The most frequent error type in the AUX-in-I condition was omission of the auxiliary and production of the bare stem, both indicating that I remained empty. For the AUX-in-C condition auxiliary omission and failure to move the auxiliary to C were the most prominent errors, both indicating that C remains empty. These data support our hypothesis that it is not the position in the syntactic tree that certain structures occupy that predicts production impairment, but rather whether or not verb or auxiliary movement is required.

### 5. General discussion

The hypothesis of the present study was that verb movement is problematic for agrammatic aphasic speakers. Because verb movement is applied differently in different languages, a cross-linguistic study was undertaken. The first experiment, with Dutch and English speaking patients, showed a discrepancy between matrix and embedded clauses for Dutch, but not for English. This finding supported the hypothesis that verb movement is a critical factor in production, since in Dutch there is verb movement in the matrix clause (which is significantly more difficult), but not in the embedded clause. In English the position of the verb in matrix and embedded clauses is the same; we therefore predicted no difference in performance for the two clause types and none was found.

To further test our verb movement hypothesis, a second experiment was conducted in English in which we elicited production of two structures that have no verb movement and one structure that does. In keeping with our hypothesis, the results showed that even though the participants showed impairments in production of all sentence types tested, the condition in which movement was required (in this case movement of the auxiliary in yes/no question) was significantly more difficult than the conditions in which no movement occurred.

The findings from these studies considered together suggest that verb movement is a critical factor in production deficits in agrammatism, and that the position that structures occupy in the syntactic tree is not. Hagiwara (1995), for example, suggests that in agrammatic aphasia the C-node is faulty, resulting in difficulty producing CP structures. Our data do not refute this notion in that yes/no questions were indeed impaired in our patients. However, on Hagiwara's account, our Dutch agrammatics should not show a verb movement deficit since the verb moves to I and not to C, unless one assumes that the finite verb in Dutch moves to C (as is, for example, on Den Besten's (1989) account).

According to Friedmann (Friedmann & Grodzinsky, 1997; Friedmann, 2000) the syntactic tree is pruned in I, between the node for tense (TP) and the node for Agreement (AgrSP), suggesting that AUX-in-I should be more impaired than

V-in-V. However, the present data show that there is no difference between the production of V-in-V and AUX-in-I in English. A possible solution to this problem is to assume, as Friedmann does, that the finite lexical verb always needs to move to I, if not overtly (such as in the Dutch matrix clause), then covertly (after Spell Out). In this way, one expects the finite lexical verb and the auxiliary to be equally impaired, since both are in I. This is not an elegant solution for two reasons. First, if one expects the syntactic tree to be impaired or inaccessible from I up, then there is no reason to expect a difference between AUX-in-I and AUX-in-C, unless one accepts a gradual disorder, something like ‘the higher in the tree, the more difficult.’ The second, and in our view more convincing reason not to assume that covert verb movement is impaired, is the relatively good performance of the Dutch agrammatic speakers in the embedded clause. If one accepts a notion such as covert movement for English, then one should accept the same for Dutch embedded clauses. Similarly, if one assumes that covert verb movement is problematic for agrammatic speakers, then this should be the case for both English and Dutch. This is contradicted by the data from the first study (and data published earlier by Bastiaanse & Van Zonneveld, 1998) that show a discrepancy between finite verb production in the matrix and the embedded clause. Specifically, Dutch agrammatic aphasic speakers are significantly better at producing object–finite verb strings in which the verb is not (overtly) moved than in producing finite verb–object strings in which the finite verb has been moved to I.

In conclusion, our view is that overt verb movement is problematic for agrammatic speakers, regardless of whether this is movement to I or to C. In agrammatic speech, non-moved auxiliaries, that are base-generated in I, are produced equally as well as non-moved finite verbs base-generated in V. Moved finite verbs (in Dutch) and moved auxiliaries (in English), however, are significantly more difficult, thus confirming our hypothesis that verb movement underlies at least some production deficits seen in agrammatism.

This theory is strengthened by the errors produced by the participants in both experiments. In the first study, where movement occurs in Dutch matrix clauses, the finite moved verbs are either omitted or not moved. In the second study, in English, where movement occurs in yes/no questions (AUX-in-C condition), the same two error types were prominent, i.e., omission of, or failure to move, the auxiliary. The strategy of the Dutch and English agrammatic speakers seems to be the same: either omit the moved element or don’t move it. These errors suggest that verb movement is problematic.

The qualitative analysis of the first study also revealed some interesting data, as there is an absolute dichotomy between the Dutch and English speaking agrammatics. The Dutch patients make word order errors, but never finiteness errors; whereas the pattern for the English speaking agrammatics is the opposite. Although it has been mentioned repeatedly that different types of Broca’s aphasia might exist (see for example Miceli, Mazzuchi, Menn, & Goodglass, 1983; Saffran et al., 1989) and that agrammatism might manifest itself differently across patients (e.g., Kolk & Heeschen, 1990) and even within patients (Bastiaanse, 1995), it is unreasonable to assume that, incidentally, all English speaking agrammatics have a morphological disorder and all Dutch speaking agrammatics a syntactic one. There is a more plausible explanation. In Dutch, verb movement is obligatory in the matrix clause and is forbidden in the embedded clause. This means that two possible word orders are allowed in Dutch: (subject)–finite verb–object (for the matrix clause) and (subject)–object–finite verb (for the embedded clause). Hence, even if the Dutch speaking agrammatics make word order errors, they produce a word order that is allowed in their grammar. In English, the word order can never be (subject)–object–finite verb

and hence, word order errors (that is, the production of an object–finite verb string) are not an option for English-speaking agrammatic patients, as it is a word order that is not in their grammar (although they may occasionally make word order errors in their narrative discourse, such as “the ball can’t go Cinderella, because she ugly.” In English, nonfinite verbs (infinitives, gerunds), however, can precede the object and thus offer an alternative when they are not able to produce a finite verb, as in *cutting a tomato*. Returning to Dutch: nonfinite verbs (infinitives and particles) *always* follow the object, they can never precede it and hence, the production of a nonfinite verb followed by an object is not an option for the Dutch speaking agrammatics as this word order is not in their grammar. We suggest that in this experiment, both populations make errors that result in strings that are allowed in their grammar.

In summary, the findings from the present experiments show that verb movement plays an important role in agrammatic speech production. While we do not assume that verb movement difficulty underlies all errors seen in agrammatism, the present findings underscore, once again, the importance of the verb in production deficits.

### Acknowledgments

The authors wish to thank Judith Hugen and Esther Ruigendijk for their help with testing the Dutch patients and Yashmeen Faroqi and Swathi Kiran for testing the English-speaking subjects. The research reported here was supported in part by the Dutch Aphasia Foundation (Bastiaanse) and the National Institutes of Health (NIH) (USA) Grant # RO1DC01948 (Thompson).

### Appendix A. Test sentences of Study 1

#### Dutch

1. Deze jongen snijdt de tomaat en deze jongen snijdt het brood; dit is de jongen die de tomaat snijdt en dit is de jongen die . . .
2. dit is de vrouw die de jongen groet en dit is de vrouw die het meisje groet; deze vrouw groet de jongen en deze vrouw . . .
3. Dit meisje omhelst de man en dit meisje omhelst de vrouw; dit is het meisje dat de man omhelst en dit is het meisje dat . . .
4. dit meisje gooit de stok en dit meisje gooit de bal; dit is het meisje dat de stok gooit en dit is het meisje dat . . .
5. Dit is de vrouw die de trui breit en dit is de vrouw die de sok breit; deze vrouw breit de trui en deze vrouw . . .
6. Deze hond krabt de vrouw en deze hond krabt de man; dit is de hond die de vrouw krabt en dit is de hond die . . .
7. Dit is het meisje dat de hond ziet en dit is het meisje dat de kat ziet; dit meisje ziet de hond en dit meisje . . .
8. Deze jongen aait de hond en deze jongen aait de kat; dit is de jongen die de hond aait en dit is de jongen die . . .
9. Dit is de man die de krant leest en dit is de man die het boek leest; deze man leest de krant en deze man . . .
10. Deze vrouw bekijkt de clown en deze vrouw bekijkt de politieagent; dit is de vrouw die de clown bekijkt en dit is de vrouw die . . .

11. Dit is het meisje dat de appel eet en dit is het meisje dat de banaan eet; dit meisje eet de appel en dit meisje . . .
12. Dit is de vrouw die de hond filmt en dit is de vrouw die de man filmt; deze vrouw filmt de hond en deze vrouw . . .
13. Dit meisje tekent het huis en dit meisje tekent de bloem; dit is het meisje dat het huis tekent en dit is het meisje dat . . .
14. Dit is de man die melk drinkt en dit is de man die wijn drinkt; deze man drinkt melk en deze man . . .
15. Dit is de hond die de vrouw volgt en dit is de hond die de man volgt; deze hond volgt de vrouw en deze hond . . .
16. Deze vrouw breit de sok en deze vrouw breit de trui; dit is de vrouw die de sok breit en dit is de vrouw die . . .
17. Dit is de jongen die de man omhelst en dit is de jongen die de vrouw omhelst; deze jongen omhelst de man en deze jongen . . .
18. Deze man filmt de hond en deze man filmt de vrouw; dit is de man die de hond filmt en dit is de man die . . .
19. Dit is de kat die de man krabt en dit is de kat die de vrouw krabt; deze kat krabt de man en deze kat . . .
20. Dit is de vrouw die de tomaat snijdt en dit is de vrouw die het brood snijdt; deze vrouw snijdt de tomaat en deze vrouw . . .
21. Dit meisje leest de krant en dit meisje leest het boek; dit is het meisje dat de krant leest en dit is het meisje dat . . .
22. Deze kat volgt de vrouw en deze kat volgt de man; dit is de kat die de vrouw volgt en dit is de kat die . . .
23. Deze jongen ziet de kat en deze jongen ziet de hond; dit is de jongen die de kat ziet en dit is de jongen die . . .
24. Deze man groet de jongen en deze man groet het meisje; dit is de man die de jongen groet en dit is de man die . . .
25. Dit is het meisje dat de kat aait en dit is het meisje dat de hond aait; dit meisje aait de kat en dit meisje . . .
26. Deze vrouw drinkt wijn en deze vrouw drinkt melk; dit is de vrouw die wijn drinkt en dit is de vrouw die . . .
27. Dit is de man die de clown bekijkt en dit is de man die de politieagent bekijkt; deze man bekijkt de clown en deze man . . .
28. Dit is de jongen die de bal gooit en dit is de jongen die de stok gooit; deze jongen gooit de bal en deze jongen . . .
29. Deze jongen eet de appel en deze jongen eet de banaan; dit is de jongen die de appel eet en dit is de jongen die . . .
30. Dit is de jongen die het huis tekent en dit is de jongen die de bloem tekent; deze jongen tekent de het huis en deze jongen . . .

#### English

1. This boy cuts the tomato and this boy cuts the bread; this is the boy that cuts the tomato and this is the boy that . . .
2. This is the woman that greets the boy and this is the woman that greets the girl; this woman greets the boy and this woman . . .
3. This girl hugs the man and this girl hugs the woman; this is the girl that hugs the man and this is the girl that . . .
4. This girl throws the stick and this girl throws the ball; this is the girl that throws the stick and this is the girl that . . .

5. This is the woman that knits the sweater and this is the woman that knits the sock; this woman knits the sweater and this woman ...
6. This dog scratches the woman and this dog scratches the man; this is the dog that scratches the woman and this is the dog that ...
7. This is the girl that sees the dog and this is the girl that sees the cat; this girl sees the dog and this girl ...
8. This boy pets the dog and this boy pets the cat; this is the boy that pets the dog and this is the boy ...
9. This is the man who read the newspaper and this is the man that reads the book; this man reads the newspaper and this man ...
10. This woman watches the clown and this woman watches the cop; this is the woman that watches the clown and this is the woman that ...
11. This is the girl that eats the apple and this is the girl that eats the banana; this girl eats the apple and this girl ...
12. This is the woman that films the dog and this is the woman that films the man; this woman films the dog and this woman ...
13. This girl draws the house and this girl draws the flower; this is the girl that draws the house and this is the girl that ...
14. This is the man that drinks milk and this is the man that drinks wine; this man drinks milk and this man ...
15. This is the dog that follows the woman and this is the dog that follows the man; this dog follows the woman and this dog ...
16. This woman knits the sock and this woman knits the sweater; this is the woman that knits the sock and this is the woman that ...
17. This is the boy that shoves the man and this is the boy that shoves the woman; this boy shoves the man and this boy ...
18. This man films the dog and this man films the woman; this is the man that films the dog and this is the man that ...
19. This is the cat that scratches the man and this is the cat that scratches the woman; this cat scratches the man and this cat ...
20. This is the woman that cuts the tomato and this is the woman that cuts the bread; this woman cuts the tomato and this woman ...
21. This girl reads the newspaper and this girl reads the book; this is the girl that reads the newspaper and this is the girl that ...
22. This cat follows the woman and this cat follows the man; this is the cat the follows the woman and this is the cat that ...
23. This boy sees the cat and this boy sees the dog; this is the boy that sees the cat and this is the boy that ...
24. This man greets the boy and this man greets the girl; this is the man that greets the boy and this is the man that ...
25. This is the girl that pets the cat and this is the girl that pets the dog; this girl pets the cat and this girl ...
26. This woman drinks wine and this woman drinks milk; this is the woman that drinks wine and this is the woman that ...
27. This is the man that watches the clown and this is the man that watches the cop; this man watches the clown and this man ...
28. This is the boy that throws the ball and this is the boy that throws the stick; this boy throws the ball and this boy ...
29. This boy eats the apple and this boy eats the banana; this is the boy that eats the apple and this is the boy that ...
30. This is the boy that draws the house and this is the boy that draws the flower; this boy draws the house and this boy ...

### Appendix B. Individual scores of the Dutch (D) and English (E) participants in Study 1 (absolute scores)

	Correct		Errors matrix clause				Errors embedded clause			
	Matrix	Embedded	-V	Order	-Finite	Other	-V	Order	-Finite	Other
D1	5	11	7	3	0	0	0	1	0	3
D2	10	8	0	2	0	3	0	6	0	1
D3	7	14	5	3	0	0	0	1	0	0
D4	7	13	0	7	0	1	0	0	0	2
D5	10	14	0	5	0	0	0	1	0	0
D6	12	14	2	1	0	0	0	1	0	0
D7	7	9	3	1	0	4	0	1	0	5
D8	3 <sup>a</sup>	10	0	0	0	3	3	0	0	1
D9	5	14	8	0	0	2	0	0	0	1
E1	13	13	1	0	0	1	0	0	0	2
E2	8	9	3	0	1	3	5	0	0	1
E3	10	10	0	0	4	1	0	0	5	0
E4	12	14	0	0	1	1	1	0	0	0
E5	12	11	1	0	0	2	4	0	0	0
E6	4	4	0	0	8	3	2	0	7	2

<sup>a</sup>This patient produced a 'dummy verb' (to do) in the matrix clause ten times (e.g., 'this boy does the stick' instead of *this boy throws the stick*).

### Appendix C. Target sentences of Study 2

1. The boy is tickling the girl
2. Is the sheriff kicking the convict?
3. Is the thief chasing the artist?
4. The judge trips the clerk
5. Is the cop stopping the driver?
6. The guest is watching the waiter
7. The woman is kissing the man
8. Is the student lifting the biker?
9. Is the thief trapping the cop?
10. The farmer carries the hunter
11. Is the boy tickling the girl?
12. The sheriff kicks the convict
13. the thief is chasing the artist
14. Is the judge tripping the clerk?
15. The cop stops the driver
16. Is the guest watching the waiter?
17. Is the woman kissing the man?
18. The student lifts the biker
19. The thief is trapping the cop
20. Is the farmer carrying the hunter?
21. The girl tickles the boy
22. Is the convict kicking the sheriff?
23. Is the artist chasing the thief?
24. The clerk is tripping the judge

25. Is the driver stopping the cop?
26. The waiter is watching the guest
27. The man is kissing the woman
28. Is the biker lifting the student?
29. Is the cop trapping the thief?
30. The hunter carries the farmer
31. Is the girl tickling the boy?
32. The convict kicks the sheriff
33. The artist is chasing the thief
34. Is the clerk tripping the judge?
35. The driver stops the cop
36. Is the waiter watching the guest?
37. Is the man kissing the woman?
38. The biker is lifting the student
39. The cop traps the thief
40. Is the hunter carrying the farmer?

#### Appendix D. Individual scores of the English participants in Study 2 (percentages correct)

	V-in-V	V-in-I	Total – movement	V-in-C + movement
E1	80	50	65	40
E2 <sup>a</sup>	33.3	0	16.7	0
E3	10	0	5	5
E4	40	10	25	0
E5	30	10	20	0
E6	80	90	85	70
E7	40	100	70	0
E8	0	20	10	10

<sup>a</sup> Only 24 items were administered.

#### References

- Bastiaanse, R. (1995). Broca's aphasia: A syntactic and/or morphological disorder? a case study. *Brain and Language*, 48, 1–32.
- Bastiaanse, R., Hugen, J., Kos, M., & Van Zonneveld, R. (2002). Lexical, morphological and syntactic aspects of verb production in Dutch agrammatic aphasics. *Brain and Language*, 80, 142–159.
- Bastiaanse, R., & Jonkers, R. (1998). Verb retrieval in action naming and spontaneous speech in agrammatic and anomic aphasia. *Aphasiology*, 12, 951–969.
- Bastiaanse, R., Jonkers, R., & Moltmaker-Osinga, U. (1996). Aspects of lexical verbs in the spontaneous speech of agrammatic and anomic patients. In R. Jonkers, E. Kaan, & A. Wiegel (Eds.), *Language and cognition* (Vol. 5). The Netherlands: University of Groningen.
- Bastiaanse, R., & Van Zonneveld, R. (1998). On the relation between verb inflection and verb position in Dutch agrammatic aphasics. *Brain and Language*, 64, 165–181.
- Berndt, R. S., Haendiges, A. N., Mitchum, C. C., & Sandson, J. (1997a). Verb retrieval in aphasia: 1. Characterizing single word impairments. *Brain and Language*, 56, 68–106.
- Berndt, R. S., Mitchum, C. C., Haendiges, A. N., & Sandson, J. (1997b). Verb retrieval in aphasia: 2. Relationship to sentence processing. *Brain and Language*, 56, 107–137.
- Chomsky, N. (1995). *The minimalist program*. Cambridge: MIT Press.
- Den Besten, H. (1989). *Studies in West Germanic syntax*. Dissertation, University of Tilburg, NL.
- Friedmann, N. (2000). Moving verbs in agrammatic production. In R. Bastiaanse & Y. Grodzinsky (Eds.), *Grammatical disorders in aphasia: A neurolinguistic perspective*. London: Whurr.

- Friedmann, N., & Grodzinsky, Y. (1997). Tense and agreement in agrammatic production: Pruning the syntactic tree. *Brain and Language*, 56, 397–425.
- Graetz, P., De Bleser, R., & Willmes, K. (1992). *Akense Afasie Test*. Lisse: Swets & Zeitlinger.
- Hagiwara, H. (1995). The breakdown of functional categories and the economy of derivation. *Brain and Language*, 50, 92–116.
- Jonkers, R. (2000). Verb finding problems in Broca's aphasia: The influence of transitivity. In R. Bastiaanse & Y. Grodzinsky (Eds.), *Grammatical disorders in aphasia: A neurolinguistic perspective*. London: Whurr.
- Kertesz, A. (1982). *The Western Aphasia Battery*. San Antonio: The Psychological Corporation.
- Kim, M., & Thompson, C. K. (2000). Patterns of comprehension and production of nouns and verbs in agrammatism: Implications for lexical organisation. *Brain and Language*, 74, 1–25.
- Kohn, S. E., Lorch, M. P., & Pearson, D. M. (1989). Verb finding in aphasia. *Cortex*, 25, 57–69.
- Kolk, H. H. J., & Heeschen, C. (1990). Adaptation and impairment symptoms in Broca's aphasia. *Aphasiology*, 4, 221–232.
- Kolk, H. H. J., & Heeschen, C. (1992). Agrammatism, paragrammatism and the management of language. *Language and Cognitive Processes*, 7, 89–129.
- Lasnik, H. (1999). On feature strength. Three minimalist approaches to overt movement. *Linguistic Inquiry*, 20, 195–217.
- Miceli, G., Mazzuchi, A., Menn, L., & Goodglass, H. (1983). Contrasting cases of Italian agrammatic aphasia without comprehension disorder. *Brain and Language*, 19, 65–97.
- Miceli, G., Silveri, M. C., Nocenti, U., & Caramazza, A. (1988). Patterns of dissociation in comprehension and production of nouns and verbs. *Aphasiology*, 2, 351–358.
- Miceli, G., Silveri, M. C., Villa, G., & Caramazza, A. (1984). On the basis of the agrammatics' difficulty in producing main verbs. *Cortex*, 20, 207–220.
- Saffran, E. M., Berndt, R. S., & Schwartz, M. F. (1989). The quantitative analysis of agrammatic production: Procedure and data. *Brain and Language*, 37, 440–479.
- Thompson, C. K., Lange, K. L., Schneider, S. L., & Shapiro, L. P. (1997). Agrammatic and non-brain damaged subjects' verb and verb argument structure production. *Aphasiology*, 11, 473–490.
- Thompson, C. K., Shapiro, L. P., Li, L., & Schendel, L. (1994). Analysis of verbs and verb argument structure: A method for quantification of agrammatic language production. *Clinical Aphasiology*, 23, 121–140.
- Zuckerman, S., Bastiaanse, R., & Van Zonneveld, R. (2001). Verb Movement in Acquisition and Aphasia: Same problem different solutions. Evidence from Dutch. *Brain and Language*, 77, 449–458.